

SIDE VIEW FOR EACH TYPE OF CONTACTS

COMMON QUOTES FOR ALL TYPE OF CONTACTS

UTSX1JC----P

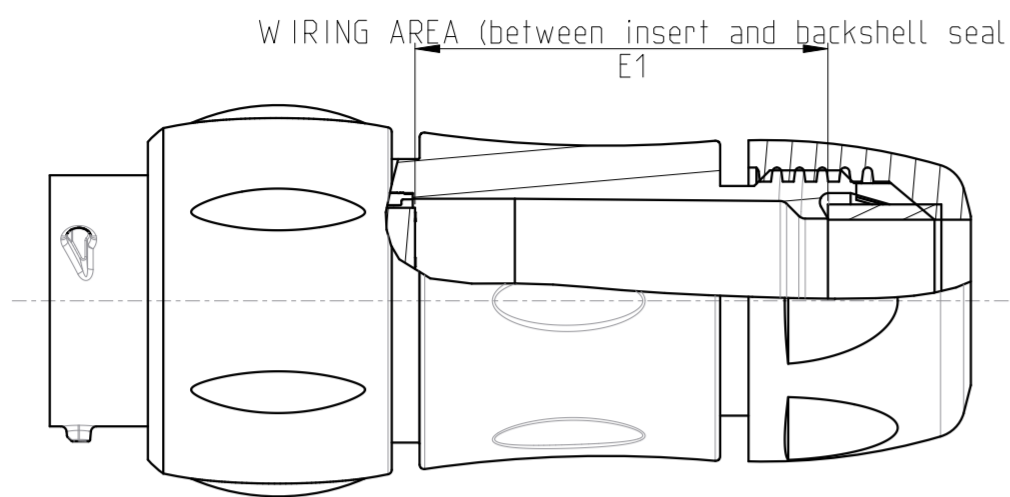

UTSX1JC----S

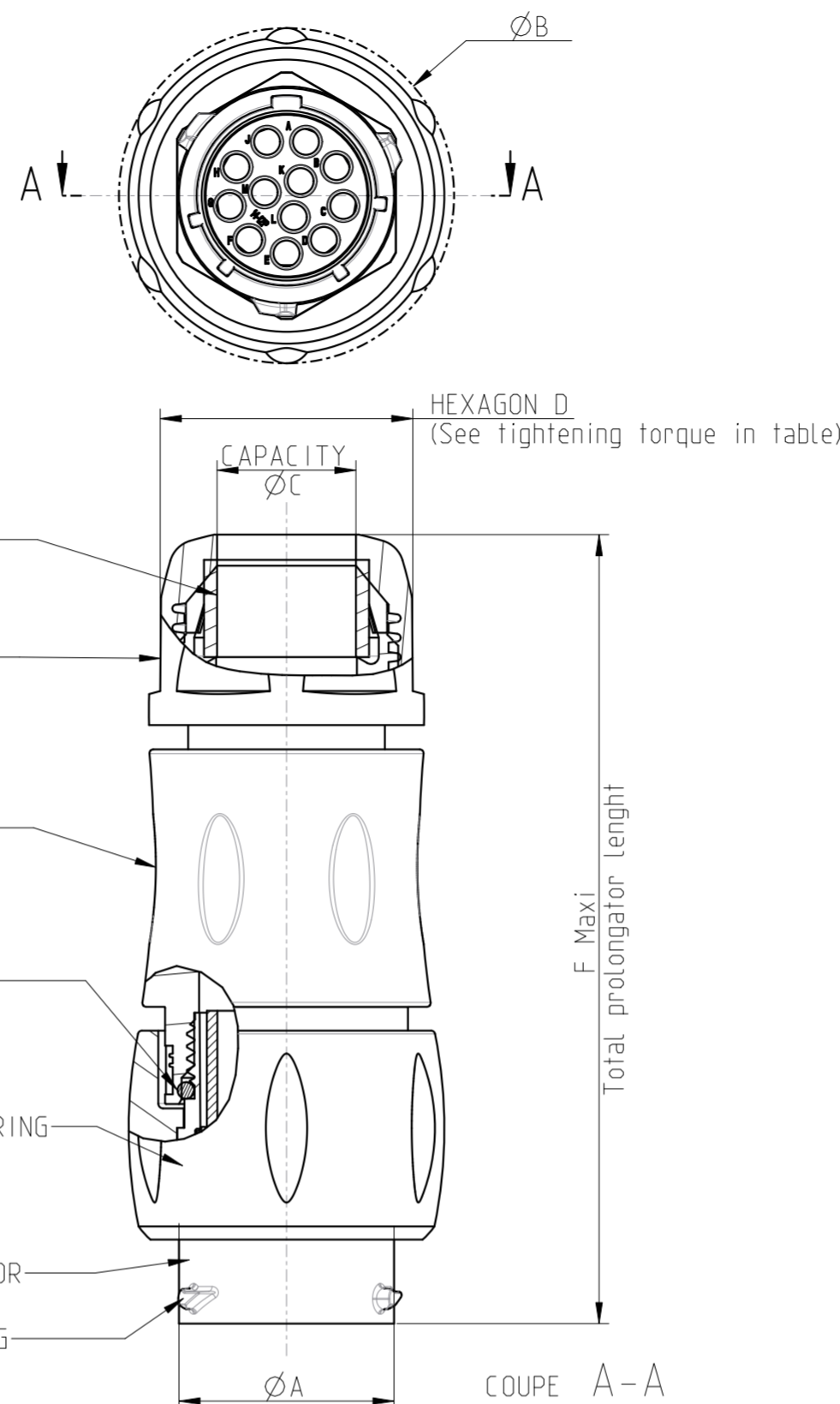
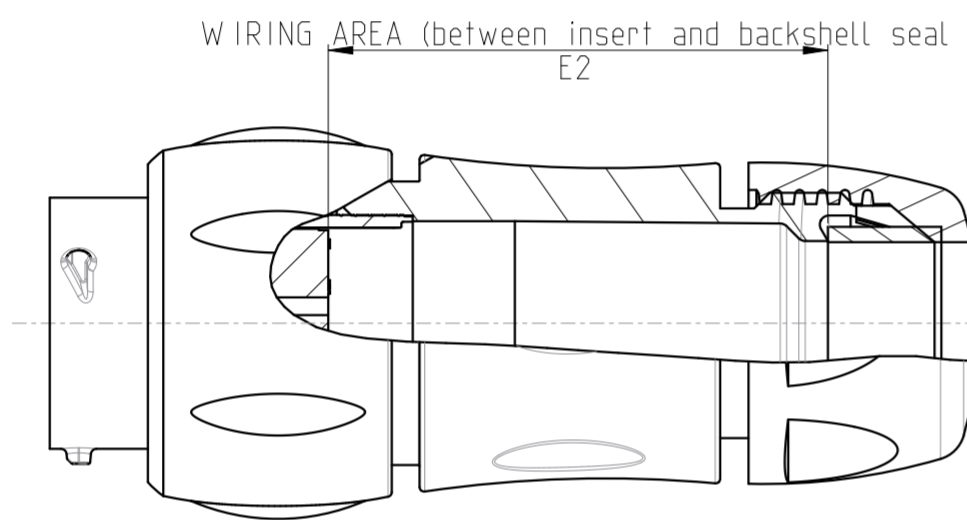

MATERIAL :

- SHELLS : PA UL94 V0, UL746C F1 Black color
- INSERT : PA UL94 V0, UL746C F1
- BACKSHELLS : PA UL94 V0 F1 Black color
- BACKSHELL Seal : CR
- O'RING : Nitril
- CONTACTS : brass + coated depending on P/N

PERFORMANCE CHARACTERISTICS :

- Operating temperature: -40°C up to 105°C
- Insulation resistance: 5000 MΩmin under 500V
- Corrosion salt spray: 500 hours
- Durability: 250 matings and unmatings
- Norm for the cable gland: NF EN 62444
- Mechanical strenght in torsion and traction forces for holding the cable : NF EN 62444 - Anchor type A
- Sealing in mated conditions with counterpart:
  - IP6x : No ingress of dust
  - IPx8 1 bar during 1 week :
  - immersion under 10 m of water.
  - IPx9K : exposure to high pressure water of cleaning equipment (IEC 60529)

NOTA:

- Contact to be ordered separately : refer to corresponding catalogue.
- Insert arrangement refer to:

UTX\_LAYOUT (Standard Version)

- This part shall be used at the place of the standard seal to accomodate with different cable Ø
- Plug, backshell and the reducing seal are delivered a kit. The backshell already includes the standard
- For these cable diameters, the mechanical strenght in torsion and traction is not applicable

SHELL SIZE	±0.2	MAX	STANDARD	REDUCING SEAL (NOTA.3)	BACKSHELL BODY	HEXAGON backshell nut		MAX		
	ØA	ØB	ØC		Tightening torque (N.m)	D	Tightening torque (N.m)	E1	E2	F
10	15.2	26.7	5 / 8	3 / 5 *	1.5	18.5	1	31	38	75
12	19.15	30.1	8 / 12	5 / 9	2.5	24	2	34	41.5	78
14	22.31	35.1	10 / 14	8 / 12	3	26	2.5	38	45.5	84
16	25.56	38	12 / 16	9 to 12* / 13	2	29	3.5	42	50	91
18	28.55	42	13 / 18	11 to 15* / 16	2.5	33	3.5	43.5	51	96

3 / 5 \* : SEE NOTA 5  
 9 to 12\* : SEE NOTA 5  
 11 to 15\* : SEE NOTA 5

P/N : CROSS REF TABLE

BASIC SERIES	UTSX	1	JC	14	19	P	-	* P/N for example
SHELL TYPE	1	Free hanging prolongator						
BACKSHELL	JC							
SHELL SIZE	10	12	14	16	18	ORIENTATIONS Normal (no digit) W.X.Y.Z		
INSERT ARRANGEMENT	See NOTA 2						TYPE OF CONTACTS P: MALE S: FEMALE	

D	21/02/2024	- Modification of the dimensions E1-E2 size 16 and 18	26163X
ISS	DATE	Latest modification - by:	Q.LECOMTE
Designed by:		J.GAMBIER	Date: 1 21/07/2020

TITLE	FREE HANGING PROLONGATOR Type 1, SIZE 10 to 18 - standard version
CONNECTEUR	UTSX

Scale	3/2	Dimensions in mm General Linear Tolerances: ± 0.2	NPRDS / PROJECT GBB
-------	-----	--	------------------------

FORMAT	A2	www.souriau.com	This document is the property of SOURIAU It must not be reproduced or communicated without permission
--------	----	-----------------	--

FORMAT	A2	SOURIAU DRG N° UTSX-0003A-C	SHEET 1 / 1
--------	----	--------------------------------	----------------

Country	Jurisdiction & Control List
FR	NOT LISTED

SOURIAU shall not be liable for any non-conformity or damage due to a use of the Products which does not comply with the Specifications issued by either of the Parties or by a third party (professional recommendation, technical notice.)